

iServer External WHITEBOX® MicroServer™

MADE IN USA CE 1 YEAR WARRANTY UL US LISTED FCC-B



\$195
EIS-W



LATE BREAKING PRODUCTS

- ✔ Connects Any Serial Device with RS-232, RS-485, or RS-422 to an Ethernet Network and the Internet
- ✔ Replace Dedicated Wiring and PC's for Serial Connections
- ✔ Handles RS-232, RS-422 and RS-485 Serial Communications
- ✔ Digital I/O Lines
- ✔ Well-Developed TCP/IP Stack
- ✔ Web Based Interface for Easy Configuration and Access Without any Special Software
- ✔ Configuration Option via Telnet and Serial
- ✔ Supports TCP, UDP, ARP, Telnet, DHCP, DNS, HTTP, and MODBUS Protocols
- ✔ Password Protection for Security
- ✔ Wall Mount Brackets for Secure Installation
- ✔ Firmware Upgradeable
- ✔ Custom Firmware and Private Labeling for OEM's
- ✔ OEM Board-Level iServer Available

The award-winning OMEGA® iServer is the simplest, easiest, most economical way to connect serial devices to an Ethernet network and the Internet.

When you type its name in a Web Browser, it serves Web pages that let you quickly and easily configure the device for your specific application without any special software.

Getting started with the iServer is very simple and easy because it can take a dynamically assigned IP address from a DHCP server on your network. This DHCP client capability is a valuable and unique feature of the OMEGA iServer that makes it extremely easy and simple to start using this device on almost any Ethernet network.

You can easily assign a static IP address to the iServer instead of a dynamic one, if necessary. The IP address can be assigned locally through its serial connection, as well as remotely over an Ethernet network via Telnet or a Web browser, using its factory default IP address.

The OMEGA iServer connects to an Ethernet Network with a standard RJ45 connector. Serial devices connect to the iServer with a standard DB-9 connector. You can select RS-232 or RS-485 (and RS-422) Serial Communications from the configuration Web page.

The iServer can be used to make an existing Serial device a "node" on an Ethernet network with a unique IP address that's accessible from any authorized computer on the LAN, WAN, or Internet.

The iServer can instead be used to create a virtual tunnel on an Ethernet/Internet network simulating a local point-to-point serial connection between a serial device and a PC. This replaces dedicated point-

to-point wiring limited to 15 m (50') on an RS-232 connection. The OMEGA iServer packages the Serial data in standard TCP/IP packets that can travel anywhere on the Ethernet LAN or over the Internet.

The OMEGA iServer is compatible with almost any device with a Serial interface such as: time clocks, security alarms, card-key access controllers, telecommunications equipment, vending machines, bar code readers, electric power meters, UPS systems, test & measurement instrumentation, PLC's, serial printers, cash registers, and many more.

You do not need to rewrite the firmware for your serial devices to work with the iServer, and in some cases might not need to change your application software. Your serial devices will function over the Ethernet network or the Internet as if they were connected directly to a PC. The COM port on the iServer simulates a local COM port on the PC.

The OMEGA iServer is compatible with wireless Ethernet. In settings where wires of any kind are not possible, the EIS-W can be connected to a Wireless Ethernet Access Point enabling simple, economical Wireless connectivity of Serial Devices.

With the OMEGA iServer: A facilities manager can monitor electric power usage over the LAN from a desk anywhere in the facility, or from anywhere on the Internet with the proper passwords and authorization. A payroll clerk can download data from time clocks to a PC anywhere on a local area network, or anywhere in the world. A manufacturing technician can use a handheld computer with Wireless Ethernet connectivity to change settings on a process controller.

The OMEGA iServer model EIS-W comes complete with full documentation, software, and AC power adaptor.

For OEM's, OMEGA offers custom labeling as well as customized application specific firmware and design engineering.

OMEGA also offers printed circuit board-level products (powered by 5 Vdc) that OEM's can incorporate in their product to add embedded Ethernet/Internet connectivity with existing serial interface. (Contact the OMEGA OEM Engineering Group.)

For industrial applications, OMEGA offers other iServer Device Servers in polycarbonate enclosures for DIN rail mounting and a 10 to 32 Vdc power source.

OMEGA iServer products provide generous technical support and a one-year limited warranty.

Specifications

Serial Interface

Interface: Software selectable RS-232, RS-422 or RS-485 (2 wire)

Connector: DB-9 (male DTE)

Data Rates: 300 to 115.2 Kbps

Characters: 7 or 8 data bits

Parity: odd, even or none

Stop Bits: 1 or 2

Flow Control: Hardware (RTS/CTS) and software (Xon/Xoff)

Digital I/O's: 4 digital Input/Output lines

Network Interface

Interface: Ethernet 10 Base-T

Connector: RJ45

Protocols: TCP/IP, UDP/IP, ARP, ICMP, DHCP, DNS, HTTP, Telnet, and MODBUS/TCP

Indicators (LED)

Power, Network Activity, and Serial Transmit/Receive

Processor

CPU: Enhanced 8051, 22 MHz

Memory: 512 kbyte flash, 16 kbyte SRAM

Management: Embedded web server, Telnet login, Serial login

Embedded Web Server

Uses: Serves dynamic web pages and Java applets (256 kbyte capacity)

Power

Input: 9 to 12 Vdc

Consumption: 2 W max. (AC adaptor included)

Environmental

Operating Temperature: 0 to 70°C (32 to 158°F)

Storage Temperature: -40 to 125°C (-40 to 257°F)

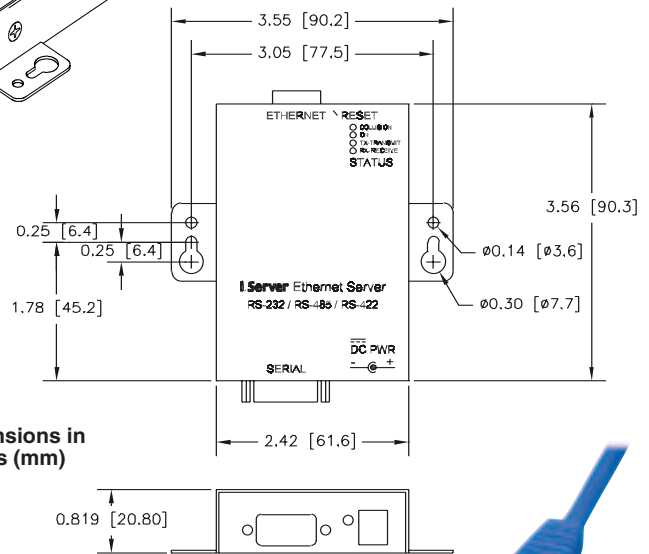
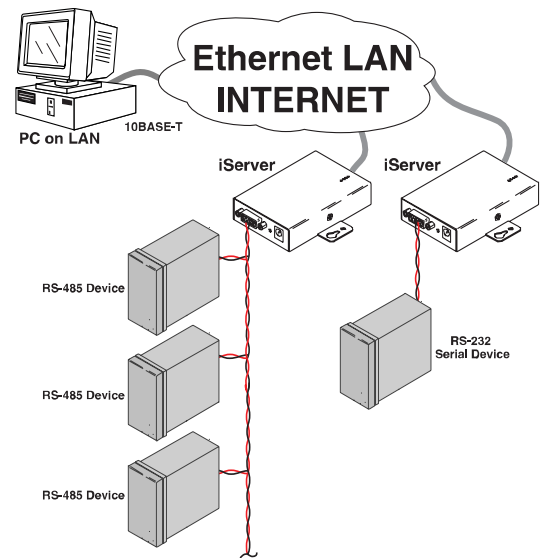
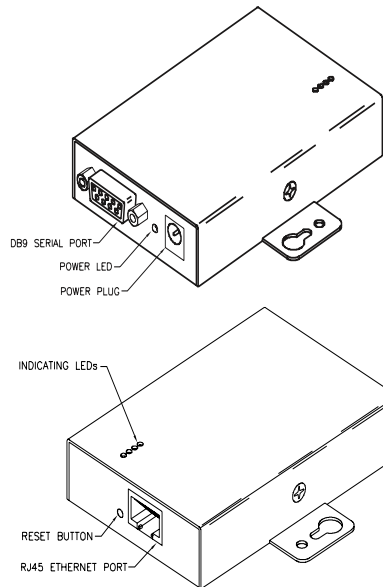

Packaging Material:

Metal case with flange mount

Dimensions: 20.8 H x 61.6 W x 90.3 D mm (0.82 x 2.42 x 3.56")

Weight: 0.18 kg (0.4 lb)

Agency Approvals

FCC-B, C/UL, CE

Software

Firmware upgradeable. Compatible with Windows 9x/ME/NT/ 2000/XP software and related utilities

Ordering Information

MicroServer™: Serial interface (RS-232, RS-422, RS-485), 10Base-T/Ethernet, diagnostic LEDs, AC power adaptor (included), CD-ROM with documentation, and printed Quick Start Guide

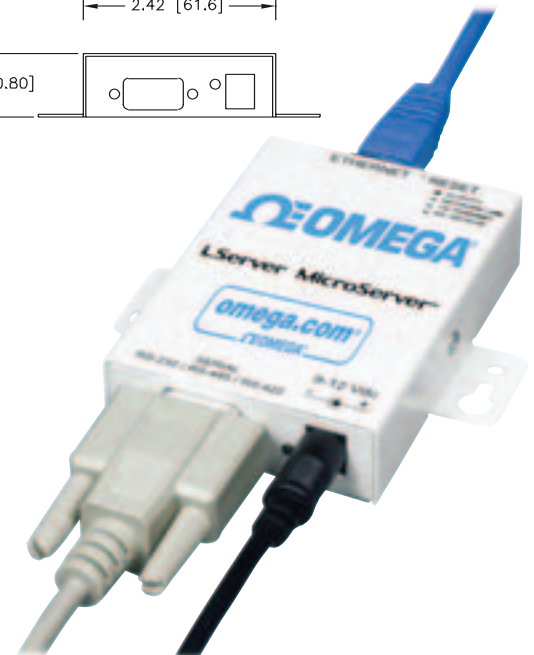

To Order (Specify Model Number)

Model No.	Price*	Description
EIS-W	\$195	External WHITEBOX® MicroServer™
iDRN-PS-1000	150	Power supply (switching), 95 to 240 Vac input, 24 Vdc output @ 850 mA (powers up to 7 units)

*Volume discounts available. Comes with complete operator's manual.

Ordering Example: EIS-W-240, 240 Vac, 50/60 Hz iServer, \$195.